

## **ADMIXTURES-ENHANCING CONCRETE PERFORMANCE**

**Mario Collepari**, Enco, Engineering Concrete, Ponzano Veneto (Italy)

**ABSTRACT.** Superplasticizers are the most important admixtures enhancing concrete performance. The development of new superplasticizers during the last decades has determined the most important progress in the field of concrete structures in terms of higher strength, longer durability, lower shrinkage and safer placement particularly in elements with very congested reinforcement. The progress from sulphonated polymer to polycarboxylate has resulted in higher water reduction at a given workability and lower slump loss.

More recently poly-functional superplasticizers have been developed which are able to completely keep the initial slump for at least 1 hr without any retarding effect on the early strength. Moreover, multi-purpose and poly-functional superplasticizers have been invented which are able to reduce drying shrinkage.

**Keywords:** Adsorption, Polycarboxylate, Polyether, Water-reduction, Slump-loss, Shrinkage, Steric hindrance, Superplasticizer, Zeta potential.

**Mario Collepari** is President of ENCO, Engineering Concrete, Ponzano Veneto (Italy). He is author or co-author of numerous papers on concrete technology and cement chemistry. He is also the recipient of several awards for his contributions to the knowledge of superplasticizers and their use in concrete.

## INTRODUCTION

Admixtures interact chemically with the ingredients of the concrete and affect its performance in the fresh and hardened state. They confer special beneficial effects to concrete. They can enhance workability of the fresh mixture, and strength or durability of the hardened concrete.

Depending on the enhanced property, chemical admixtures can be classified as water reducers, superplasticizers, accelerators, retarders, air-entraining agents, corrosion inhibitors, alkali-aggregate expansion inhibitors, shrinkage reducing admixtures, etc. Two excellent handbooks [1,2] and seven interesting international conferences [3-9] are available on this important subject of the concrete science and technology. However, due to the space limitations only the recent progress of superplasticizers will be examined in this paper.

## WHY SUPERPLASTICIZERS ARE IMPORTANT

The most important improvement in concrete technology during the 30 last years has been the use of superplasticizers.

The reasons that superplasticizers are much more important than any other chemical admixture is the number of improvements which can be achieved by its use. Figure 1 summarises these schematically.

When a superplasticizer is used as a water reducer at a given workability (I in Figure 1), it improves the properties of hardened concrete and, in particular, increases strength and durability due to the reduction in capillary porosity and permeability, both related to a lower water-cement ratio ( $w/c$ ).

An other mode of use of superplasticizers involves reduction of both water and cement, so that workability and strength of the concrete with superplasticizer are the same as those of the control concrete without admixture (II in Figure 1). Since superplasticizers in this case act as cement reducers, they are capable of reducing the heat of hydration, a property that is useful for concreting in hot climates or massive structures. There is also a beneficial effect on the reduction in shrinkage and creep due to the higher aggregate/cement ratio related to the reduction in cement content and the increase of aggregate compensating the volume decrease of cement and water.

Finally, if superplasticizers are added without modifying water and cement content, concrete workability improves (III in Figure 1). This is perhaps the most useful use of superplasticizers for placing concrete in areas of high steel content that require a more workable mixture.

The changes (I) and (II) in the presence of superplasticizers can be carried out without admixture by increasing the cement-content (IV) or both cement and water at a given  $w/c$  (V) respectively. Both changes (IV) and (V) occur with higher shrinkage, creep and heat of hydration for the increase of the cement content.

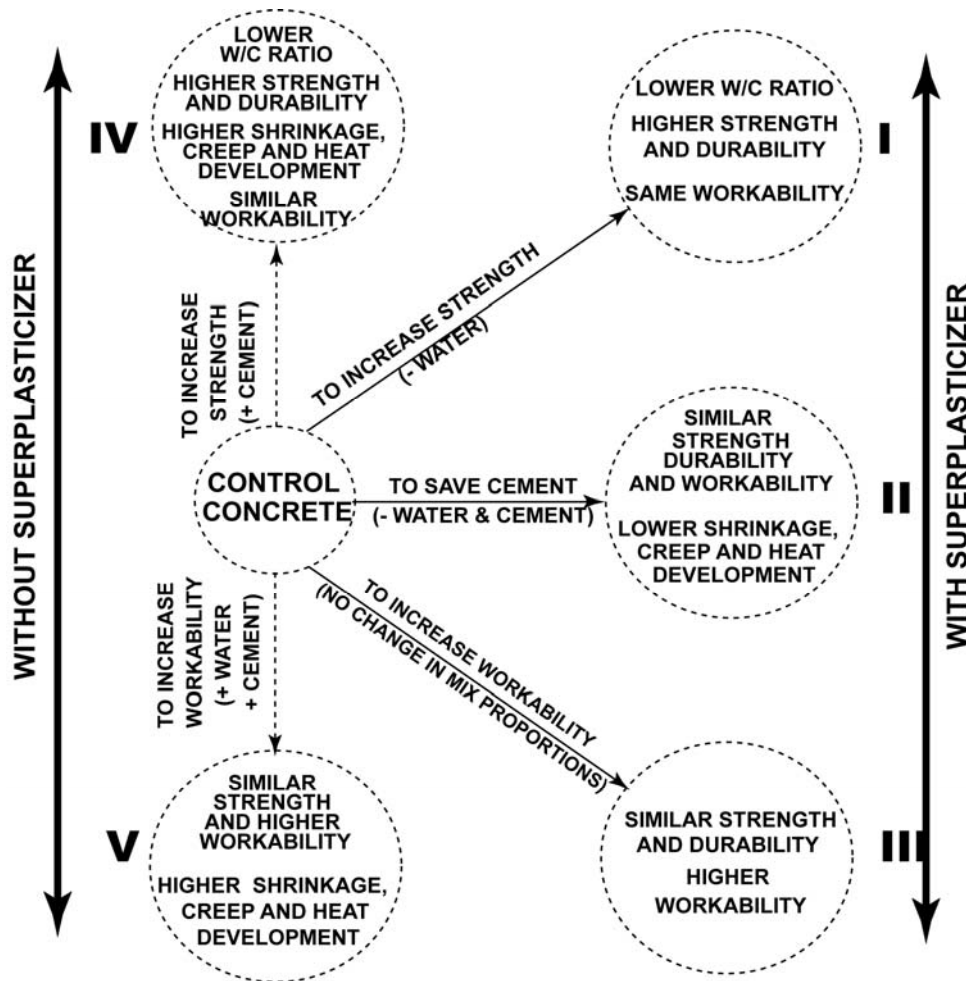


Figure 1 Schematic diagram of the effect of superplasticizers on fresh and hardened concrete.

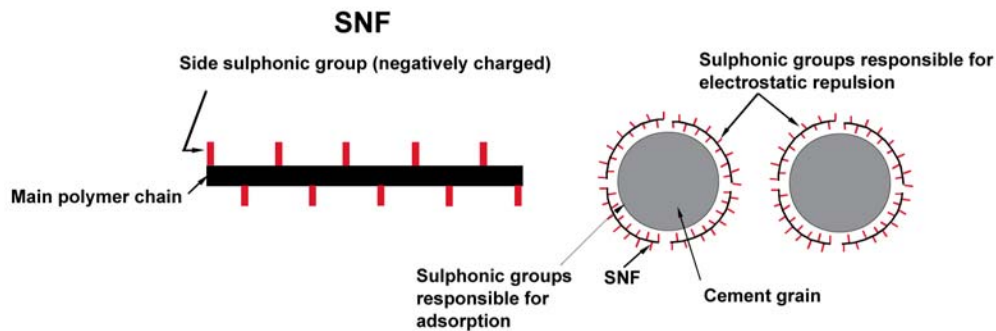
### THE PROGRESS IN SUPERPLASTICIZERS

During the last three decades the main ingredients of the superplasticizers were synthetic water-soluble polymers such as sulfonated melamine formaldehyde (SMF) condensate, sulfonated naphthalene formaldehyde (SNF) condensate, and modified sugar-free lignosulfonate (MLS). Advances in superplasticizers, containing alternative water soluble synthetic products, have been proposed in the last decade [10-17] to reduce the slump-loss drawback which can partly or completely cancel the initial technical advantage associated with the use of superplasticizers (low  $w/c$  ratio or high slump level). More recently, these new superplasticizers - all based on the family of polycarboxylate polymers (PC) - have been deeply investigated, and numerous papers on these admixtures were presented at the CANMET-ACI International Conference on "Superplasticizers and Other Chemical Admixtures" [18-24].

Besides a lower slump loss, PC-based superplasticizers perform better than the traditional sulfonated polymers even in terms of either higher reduction in the  $w/c$  at a given workability, or higher slump level at a given mixture composition.

## MECHANISMS OF ACTION OF SUPERPLASTICIZERS

Superplasticizers cause dispersion into smaller cement particles of coarse agglomerates which predominate in the cement paste of the concrete mix. Due to the dispersion effect, there is a fluidity increase in the cement mixture. In the past time the dispersion effect was ascribed only to the development of the same electrostatic (negative) charge on the cement particles [23]. The electrostatic attractive forces, existing among cement particles and causing agglomeration, would be neutralized by the adsorption of anionic polymers negatively charged, such as SNF or SMF, for the presence of  $\text{SO}_3^-$  groups on the surface of cement particles. The dispersion of cement particles would be related with the electrical repulsion produced by the negatively charged groups ( $\text{SO}_3^-$ ) on the other side of the main polymer chain (Figure 2).



**Figure 2 Schematic picture of sulfonated polymer (SNF) and its electrostatic repulsion effect on the dispersion of cement particles.**

The electrostatic repulsion of cement particles was determined through zeta potential measurements. Additional available experimental results did not confirm this mechanism for the superplasticizing action of the acrylic polymers [13, 16, 17, 19-21]. Table 1, for instance, indicates that PC-based superplasticizers produce negligible zeta potential change (0.3-5 mV), with respect to that caused by SNF-based admixtures (23-28 mV), in aqueous suspensions of cement particles [19].

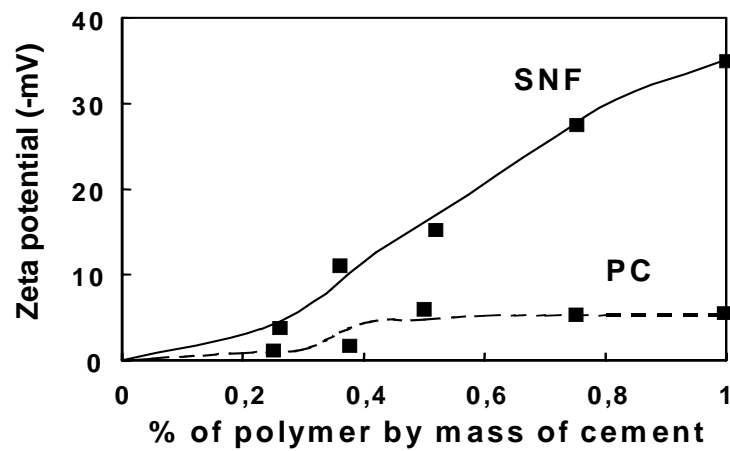
Figure 3 indicates that the zeta potential of cement particles treated by PC appears to be much lower than those recorded in the presence of SNF. In particular, when 0.3% of PC by mass of cement was used, the cement particles appeared to be almost electrically neutral.

These results would indicate that the dispersion of cement particles, responsible for the fluidity increase caused by superplasticizer, is not necessarily related to the electrostatic repulsion associated with zeta potential measurements. It would seem that, at least for the acrylic polymer-based admixtures, the polymer adsorption itself, rather than the electrostatic repulsion, is responsible for the dispersion of large agglomerates of cement particles into smaller ones resulting in a remarkable increase in the fluidity of cement mixes.

**Table 1 Zeta potential of cement particles in aqueous suspension with superplasticizers [19].**

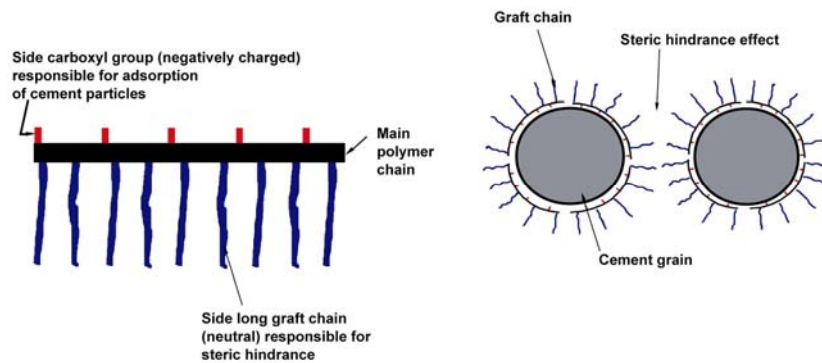
<i>SUPERPLASTICIZER</i>	<i>MAIN COMPONENT</i>	<i>ZETA-POTENTIAL (-MV)</i>
A	PC	5.0
B	PC	0.3
C	PC	1.0
D	PC	4.0
E	PC	4.0
F	PC	2.0
G	SNF	23.0
H	SNF	28.0

PC = Polycarboxylate - SNF = Sulphonated Naphtalene Formaldehyde Condensate



**Figure 3 Zeta potential of cement pastes with PC or SNF as a function of polymer dosage [12].**

The dispersion mechanism performed by the PC-based superplasticizers could be related more to a steric hindrance effect (produced by the presence of neutral side long graft chains) rather than to the presence of negatively charged anionic groups ( $\text{COO}^-$ ) which are responsible for the adsorption of the polymers on the surface of cement particles (Figure 4). In other words, the graft chains of the polymer molecules on the surface of cement would hinder by themselves from flocculating into large and irregular agglomerates of cement particles (Figure 4).

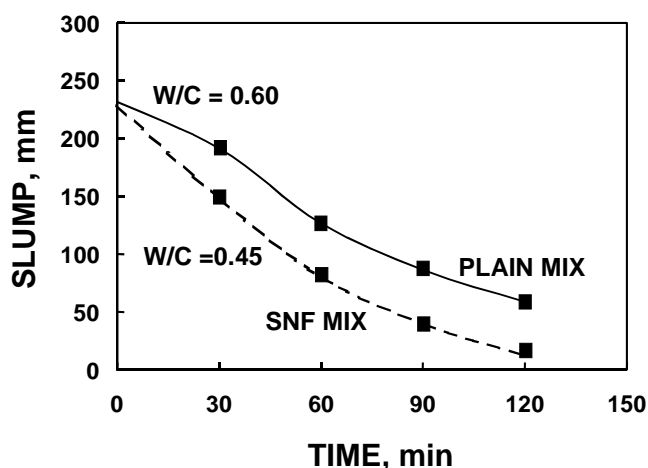


**Figure 4 Schematic picture of the polycarboxylate (PC) superplasticizer and its steric hindrance effect on the dispersion of cement particles.**

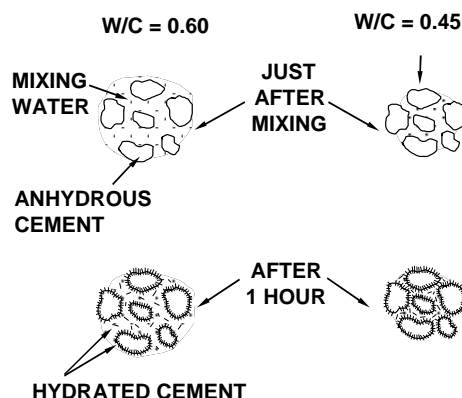
### PROGRESS IN SLUMP RETENTION

Slump loss appears to be the most serious problem at least for ready mixed concrete industries. When a concrete mix must be transported for a long time, particularly in hot weather, it should keep as far as possible its initial slump level to avoid the practice of redosing the concrete with water above and beyond that required in the mix design. Results of investigations of retempered concrete indicate that many of the properties of the hardened concrete (strength, durability, abrasion resistance, etc.) are significantly affected, since retempered concrete does not perform as well as concrete which has not been retempered [26]. However, slump loss is un-avoidable because of the intrinsic requirement for cement mixes which should set and harden in a relatively short time. Therefore, a right and proper compromise would be a zero-slump-loss concrete mix for about 1 hour. By using superplasticizers based on SNF or SMF polymers it is not easy to achieve this target, because in general slump loss is higher in superplasticized concrete with respect to the corresponding plain mix at given initial slump (Figure 5). The lower the  $w/c$ , the higher is the slump loss for the same initial slump level. It seems that the lower  $w/c$  in superplasticized concrete and the consequent lower distance among cement particles (Figure 6) cause a more significant slump loss when the same amount of water is lost through evaporation or by reaction with cement during the transportation time.

Several methods have been adopted to control the rate of slump loss. One method is to add the superplasticizer at the point of discharge but there are some practical problems associated with this approach. For instance, the concrete into the truck-mixer before the superplasticizer addition would be too stiff when a high-quality concrete, (with low  $w/c$ ), should be produced. Moreover, dosing the superplasticizer at the work site is too time consuming and does not allow an accurate control of the final slump and admixture dosage.



**Figure 5 Slump-loss at 20°C for plain and superplasticized mixes at the same initial slump. Superplasticizer: 0.4% as dry SNF polymer by weight of cement.**



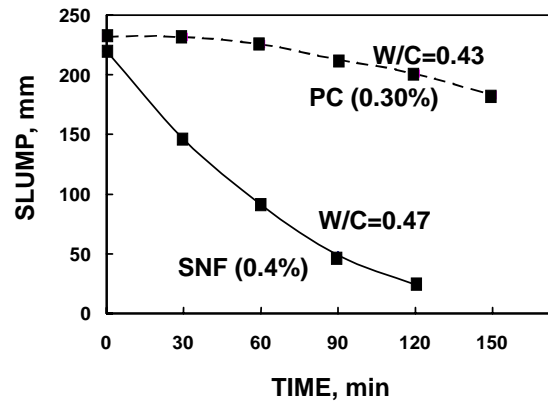
**Figure 6 Schematic picture of cement paste in a plain ( $w/c = 0.60$ ) and superplasticized concrete ( $w/c = 0.45$ ).**

Other methods to control slump loss include adding a higher than normal dosage of superplasticizer or using some type of retarding admixture in the formulation. However, there are some limits in this approach, because sometimes the final effect is to produce concrete with un-acceptable low early strength or, surprisingly, to aggravate more seriously slump loss. For instance, slump loss accompanied by a surprisingly quick set may sometimes occur by using retarders such as sugar, sucrose, corn syrup or calcium lignosulfonate [27]. The cement content, as well as the chemical and mineralogical composition of cement, play an important role in determining such a singular slump loss although the detailed mechanism is not clear: it seems that the content of  $C_3A$ , gypsum and alkali, as well as the form of calcium sulfate used as set regulator, can affect the rate of slump-loss.

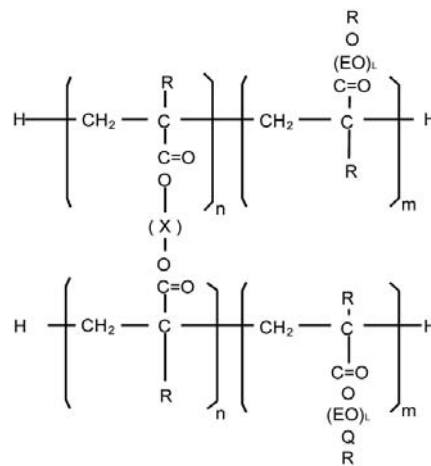
Also redosing the superplasticizer at different intervals of time has been suggested [28] to reduce slump-loss, but this method appears to be not always easy to be adopted in practice. Moreover, the total dosage of superplasticizer, as well as the relative cost, cannot be kept under control according to a given plan.

Therefore a superplasticizer is required which by itself is capable to maintain the slump for a long period of time independently of the temperature or the type and content of cement. Collepari et al. [13] studied the effects of a PC-based superplasticizer on the properties of ready-mixed concrete mixtures. This admixture acts as both an immediate superplasticizer and a slump loss reducing agent, and appears to be more effective than that based on SNF. Although these superplasticizers have been used with different contents of active polymer (0.30% versus 0.40%), the PC based superplasticizer was more effective than that based on SNF for the water reducing capability ( $w/c = 0.43$  versus 0.47) as well as for the maintainance of the initial slump level (Figure 7).

Tanaka et al. [17] studied the effect of a CLAP-based superplasticizer on the slump -loss of concrete mixture. This superplasticizer is a partially cross-linked copolymer of acrylic acid and polyethylene glycol mono-alkyl ether (Figure 8). According to Tanaka and coworkers the cross-linked polymer is hydrolyzed by the alkaline water phase of the cement paste and then converted into a PC-based polymer (Figure 9). The negative carboxylic groups due to the alkaline hydrolysis would be adsorbed on cement surface of cement particles and then would be responsible for the dispersion of cement particles and the fluidizing action of the admixture. The low slump-loss effect of this superplasticizer should be related with increasing number of the protruding side chains of the acrylic polymer which would prolong the dispersion of hydrated cement particles through a steric hindrance effect.

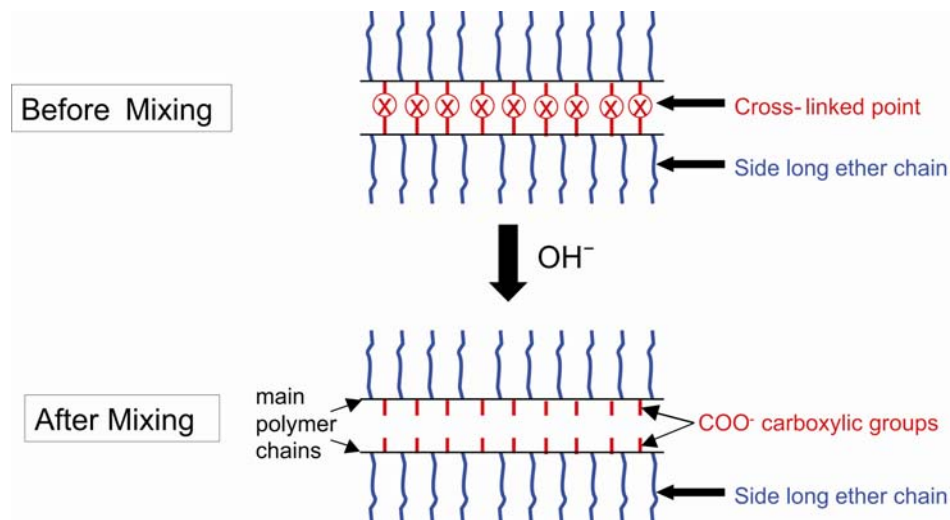


**Figure 7** Slump loss of superplasticized concretes at 20°C with PC or SNF polymer based admixtures [13]. Percentages on the curves refer to dry polymer.



**Figure 8** Chemical Structure of CLAP (Cross-Linked Acrylic Polymers). X is the cross linking group.



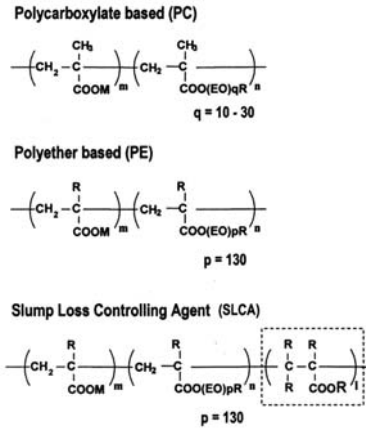


**Figure 9 CLAP-based superplasticizer hydrolyzed by the alkaline water of cement paste: the number of  $\text{COO}^-$  progressively increases with time and this is responsible for the low slump loss.**

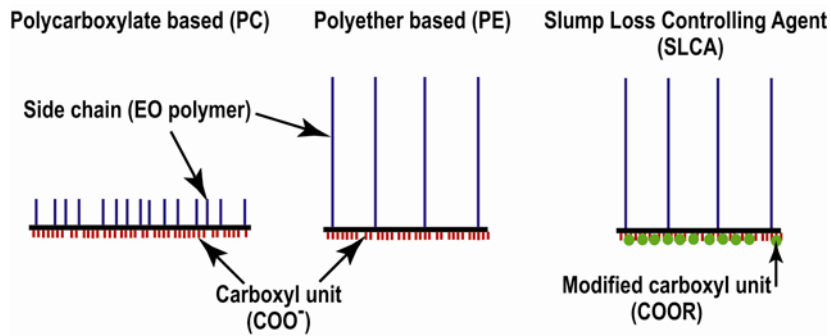
Hanada et al. [22] developed a new family of acrylic polymers based on the following changes with respect to the PC-based superplasticizer:

- a polyether (PE) based superplasticizer with much longer side chains of ethylene oxide (EO): 130 moles of EO instead of 10-25 moles as in traditional PC-based superplasticizer (Figure 10); this change produces a lower adsorption speed and reduces the typical retarding effect related to the early adsorption;
- a modified PE-based superplasticizer where a great number of carboxylic groups are replaced by a slump-loss controlling agent (SLCA) to achieve a still higher slump retention with minimal setting retardation: indeed, due to the relatively low number of carboxylic groups in SLCA (Figure 11) the initial adsorption and the dispersing effect are negligible as well as the setting retardation; however, subsequently to the hydrolytic effect related with the  $\text{OH}^-$  presence in the aqueous phase of the cement paste, the number of carboxylic units increases (Fig. 12) and the slump can still increase by prolonging the mixing time due to the increasing adsorption of the polymer on the surface of the cement particles.

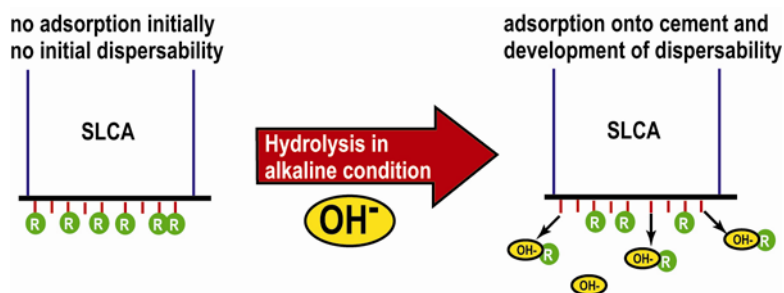
The behaviour of fresh concrete in the presence of PC and SLCA-based superplasticizers is schematically shown in Figure 13.



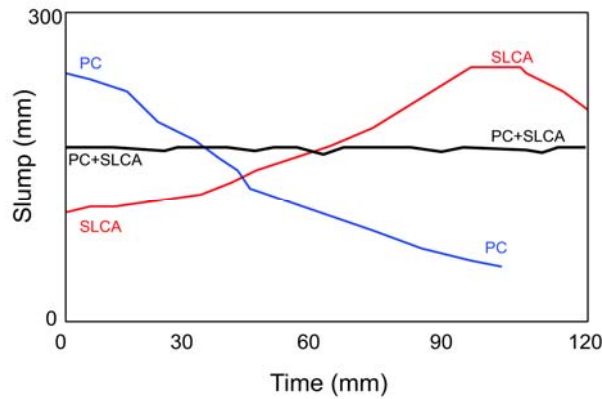
**Figure 10** The chemical structure of polycarboxylate type (PC), polyether type (PE) and slump-loss-controlling agent superplasticizer (SLCA);  $q$  and  $p$  are the number of moles of EO in PC and PE or SLCA polymers [22].



**Figure 11** The schematic molecular structure of polycarboxylate type (PC), polyether type and slump-loss-controlling agent superplasticizer (SLCA) [adapted from 22].

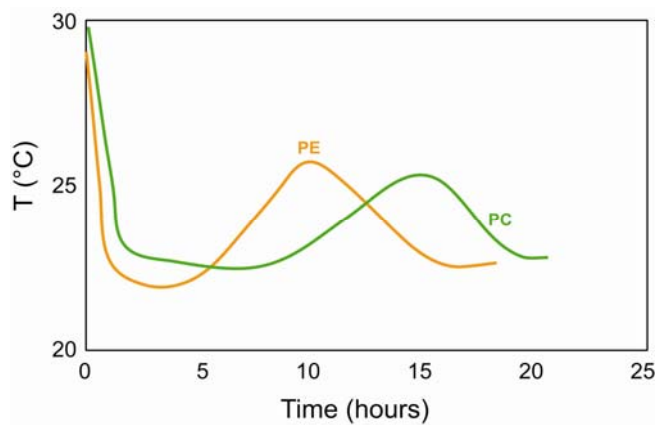


**Figure 12** The mechanism and the hydrolysis reaction of SLCA in alkaline condition of cement paste [adapted from 22].

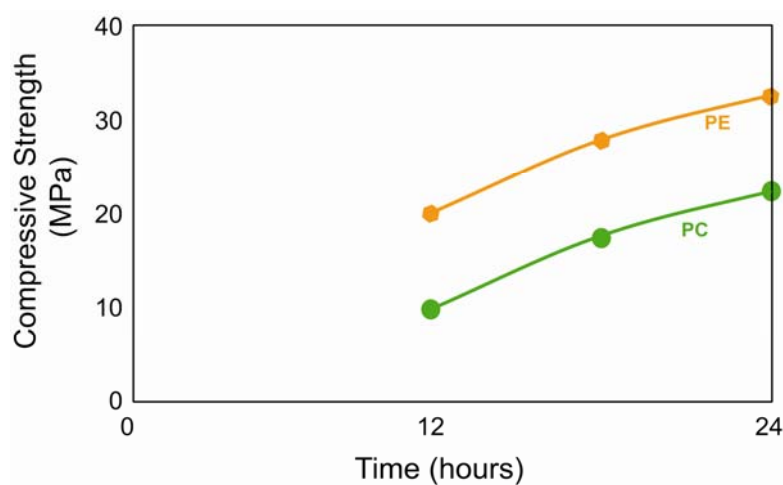


**Figure 13 Schematic trend in the slump loss behaviour with different acrylic superplasticizers (PC, SLCA, PE+SLCA) in concrete mixtures with CEM II A/L 32.5R ( $340 \text{ kg/m}^3$ ),  $w/c = 0.45$ .**

Figure 14 schematically shows the heat of cement hydration and Figure 15 shows the concrete hardening in the presence of PC or PE acrylic superplasticizer.



**Figure14 Heat development in Portland cement pastes with PE or PC polymers.**



**Figure15 Compressive strength development of concrete with PE or PC.**

Sugiyama et al. [29] synthesized a new series of superplasticizers in which functional groups of EPBE acting as shrinkage reducing agent (SRA), capable of reducing surface tension, were attached to the structure of various polycarboxylate polymers (Figure 16). Figure 17 shows the drying shrinkage behaviour of concretes with PC-based superplasticizer or modified PC-based admixture: the drying shrinkage of the latter is lower than that of the former.

Nakanishi et al. [24] invented an other multi-function and multi-purpose admixture incorporating a shrinkage reducing group (based on diethylene glycol monobutyl ether) acting as SRA on the PC chain acting as water reducing agent.

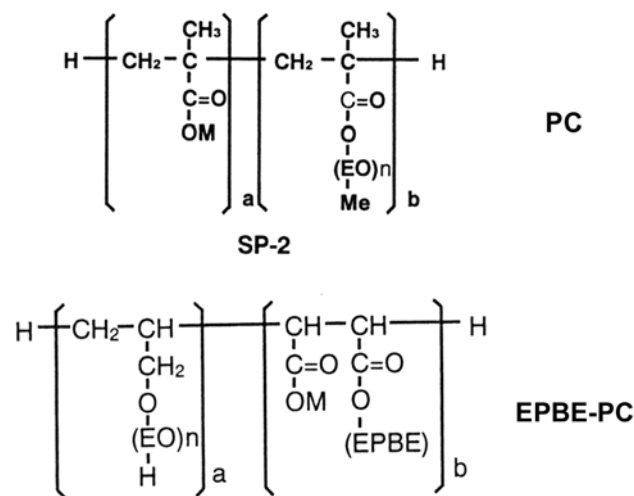


Figure 16 Chemical structures of PC and EPBE-PC [29].

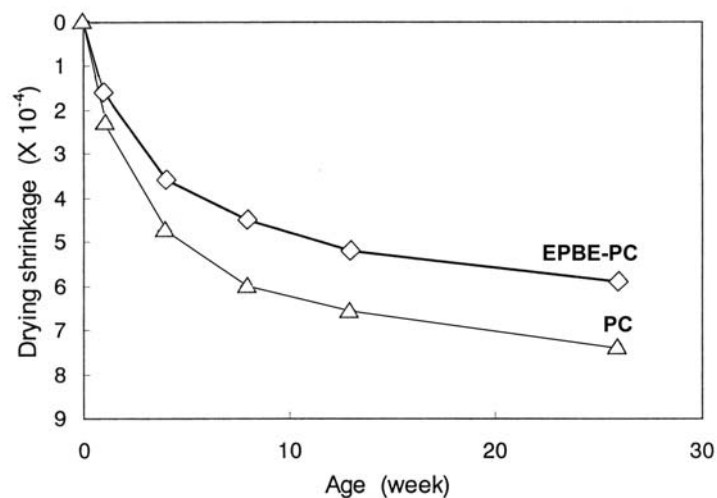


Figure 17 Shrinkage of concretes with PC-based superplasticizer or modified PC-based superplasticizer by EPBE groups [29].

## CONCLUSIONS

Superplasticizers are able to enhance the placing characteristics of concrete mixtures by increasing the workability level at a given  $w/c$ . Therefore they allow to make easy placement of concrete mixtures even with low  $w/c$  as required by strength or durability reasons.

The main drawback of superplasticized concrete mixtures with sulphonated polymer-based admixtures is the slump-loss. This can reduce or cancel the advantage of using these superplasticizers particularly in hot weather, with long transportation times and reactive cements.

A family of superplasticizers based on acrylic polymers is available with improved placing characteristics: a) flowing concretes can be produced at lower  $w/c$  with respect to concrete mixtures containing sulphonated superplasticizers; b) the slump-loss is much more reduced with respect to concrete mixes with sulphonated superplasticizers; c) multi-purpose superplasticizers with shrinkage reducing properties have been invented by incorporating special functional groups on the PC chain.

## REFERENCES

1. RAMACHANDRAN V.S., *Concrete Admixtures Handbook - Properties, Science, and Technology*, Noyes Publication, II Edition.
2. RIXOM R. AND MAILVAGANAM N., *Chemical Admixtures for Concrete*, E & FN Spon Publication, III Edition.
3. Proceedings of International Symposium on Superplasticizers in Concrete, Ottawa, Canada, ACI SP 62, (1978).
4. Proceedings of the Second International Conference on Superplasticizers in Concrete, Canada, Centre for Mineral and Energy Technology and American Concrete Institute, Ottawa, Giugno, ACI SP 68, (1981).
5. Proceedings of Third International Conference on Superplasticizers and Other Chemicals in Concrete, Ottawa, Canada, October 4-6, (1989).
6. Proceedings of Fourth CANMET/ACI International Conference on Superplasticizers and Other Chemical Admixtures in Concrete, Montreal, Canada, 11-14 Ottobre (1994).
7. Proceedings of the Fifth CANMET/ACI International Conference on "Superplasticizers and other Chemical Admixtures in Concrete", ACI SP 173, Rome, Italy, 7-10 October (1997).
8. Proceedings of Sixth CANMET/ACI International Conference on Superplasticizers and Other Chemical Admixtures in Concrete, Nice, France, 10-13 October (2000).
9. Proceedings of Seventh CANMET/ACI International Conference on Superplasticizers and Other Chemical Admixtures In Concrete, ACI SP 217, Berlin, Germany, 20-24 October (2003).
10. FUKUDA K., MIZUNUMA T., IZUMI T., IIZUKA M., HISAKA M.M., *Slump Control and Properties of Concrete with a New Superplasticizer. I: Laboratory studies and tests methods*, Proceedings of the Intern. RILEM Symposium on "Admixtures for Concrete.

- Improvement of Properties, Editor: E. Vasquez, Chapman & Hall, London, pp 10-19 (1990).
11. YAMAKAWA I., KISHTIANI K., FUKUSHI I., KUROHA K., *Slump Control and Properties of Concrete with a New Superplasticizer. II. High strength in situ concrete work at Hicariga-Oka Housing project*, RILEM Symposium on "Admixtures for Concrete. Improvement of Properties", Editor: E. Vasquez, Chapman & Hall, London, pp 94-105 (1990).
  12. COLLEPARDI M., *The World of Chemical Admixtures in Concrete*, Proceedings of the Congress "Our World in Concrete and Structures", Singapore, pp 63-72 (1993).
  13. COLLEPARDI M., COPPOLA L., CERULLI T., FERRARI G., PISTOLESI C., ZAFFARONI P., QUEK F., *Zero Slump Loss Superplasticized Concrete*, Proceedings of the Congress "Our World in Concrete and Structures", Singapore, pp 73-80 (1993).
  14. COLLEPARDI M., *Advances in Chemical Admixtures for Concrete*, Proceedings of the "Advances in Cement and Concrete", Editors: M.W. Grutzeck and S.L. Sarkar, Durham, U.S.A., pp. 257-291 (1994).
  15. COLLEPARDI M., *Superplasticizers and Air-Entraining Agents: State of the Art and Future Needs*, Proceedings of the "V.M. Malhotra Symposium. Concrete Technology: Past, Present, Future", Editor: P.K. Mehta, S. Francisco, U.S.A., pp. 399-416 (1994).
  16. UCHIKAWA H., *Hydration of Cement and Structures Formation and Properties of Cement Paste in the Presence of Organic Admixtures*, Proceedings of the "Concrete in The Service of Mankind", Editors: R.K. Dhir and M.J. McCarthy, pp. 3-47 (1995).
  17. TANAKA M., MATSUO S., OHTA A. and VEDA M., *A New Admixture for High Performance Concrete*, Proceedings of the "Concrete in The Service of Mankind", Editors: R.K. Dhir and M.J. McCarthy, pp. 291-300 (1996).
  18. JEKNAVORIAN A.A., ROBERTS L.R., JARDINE L., KOYATA H. and DARWIN D.C., *Condensed Polyacrylic Acid-Aminated Polyether Polymers as Superplasticizers for Concrete*, Proceedings of the Fifth International Conference on "Superplasticizers and Other Chemical Admixtures" Editor V.M. Malhotra, ACI SP-173, Rome, Italy, pp. 55-82 (1997).
  19. SAKAI E. and DAIMON M., *Dispersion Mechanisms of Alite Stabilized by Superplasticizers Containing Polyethylene Oxide Graft Chains*, Proceedings of the Fifth International Conference on "Superplasticizers and Other Chemical Admixtures" Editor V.M. Malhotra, ACI SP-173, Rome, Italy, pp. 187-202 (1997).
  20. OHTA A., SUGIYAMA T. and TANAKA Y., *Fluidizing Mechanism and Application of Polycarboxylate-Based Superplasticizers*, Proceedings of the Fifth International Conference on "Superplasticizers and Other Chemical Admixtures" Editor V.M. Malhotra, ACI SP-173, Rome, Italy, pp. 359-378 (1997).
  21. SHONAKA M., KITAGAWA K., SATOH H., IZUMI T. and MIZUNUMA T., *Chemical Structures and Performance of New High-Range Water-Reducing and Air-Entraining Agents*, Proceedings of the Fifth International Conference on "Superplasticizers and Other Chemical Admixtures" Editor V.M. Malhotra, ACI SP-173, Rome, Italy, pp. 599-614 (1997).
  22. HAMADA D., SATO H., YAMAMURO H., IZUMI T., and MIZUNUMA T., *Development of Slump-Loss Controlling Agent with Minimal Setting Retardation*, Proceedings of Seventh CANMET/ACI International Conference on Superplasticizers and

- Other Chemical Admixtures In Concrete, ACI SP 217, Berlin, Germany, 20-24 October, pp. 127-142 (2003).
23. COMPATER C., NONAT A., POURCHET S., MOSQUET M., and MAITRASSE P., *The Molecular Parameters and the Effect of Comb-Type Superplasticizers on Self-Compacting Concrete: A Comparison of Comb-Type Superplasticizer Adsorption onto a Basic Calcium Carbonate Medium in the Presence of Sodium Sulphate*, Proceedings of Seventh CANMET/ACI International Conference on Superplasticizers and Other Chemical Admixtures In Concrete, ACI SP 217, Berlin, Germany, 20-24 October, pp. 195-210 (2003).
24. NAKANISHI H., TAMAKI S., YAGUCHI M., YAMADA K., KINOSHITA M., ISHIMORI M., and OKAZAWA S., *Performance of a Multifunctional and Multipurpose Superplasticizer for Concrete*, Proceedings of Seventh CANMET/ACI International Conference on Superplasticizers and Other Chemical Admixtures In Concrete, ACI SP 217, Berlin, Germany, 20-24 October, pp. 327-342 (2003).
25. COLLEPARDI M. and RAMACHANDRAN V.S., *Effect of Admixtures*, Proceedings of the 9th International Congress on the Chemistry of Cement, New Dehly, India, Vol. 1, Theme III D, pp. 529-570 (1992).
26. ANDERSON F. and CARRASQUILLO R.L., *The Effects of Withholding Mixing Water and Retempering on Properties of Concrete*, Res. Rep. 117-1, Center for Transportation Research, The University of Texas at Austin, USA (1988).
27. GREEN A., *A Setting Problem Involving White Cement and Admixture*, Transportation Research record, N° 564, pp. 21-26 (1976).
28. MALHOTRA V.M. and RAMACHANDRAN V.S., *Superplasticizers*, Chapter 7, pp. 410-506, in "Concrete Admixtures Handbook. Properties, Science and Technology", Editor: V.S. Ramachandran, 2nd ed., Noyes Publications, Park Ridge, New Jersey, USA (1995).
29. SUGIYAMA T., OHTA A. and TANAKA Y., *Shrinkage Reducing Type of Advanced Superplasticizer*, Proceedings of the CANMET/ACI Symposium on "Advances in Concrete Technology", pp. 189-200, (2000).